

USER MANUAL

Product Name	EK-AI7687HXB/EK-AI7697HXB/EK-AI7697HDXB HDK User Guide MT76X7 IoT SiP Module
Version	E
Doc No	902-10401
Date	Mar. 25, 2020



AcSiP Technology Corp.

3F,-1 No.207,Fusing Rd., Taoyuan City, Taoyuan Dist., Taoyuan City 33066, Taiwan(R.O.C.)
T. +886 3 286-8388 F. +886 3 347-5000

A IoT Solution Company

www.acsip.com.tw

Document History

Date	Revised Contents	Revised by	Version
Aug 05 th ,2016	Initial Version	Kevin	A
Dec 27 th ,2016	Add Dimension Drawing	Kevin	B
Mar 20 th ,2017	Application circuit modified for RST/GPIO1 connection	Chunyi	C
Jun 04 th ,2019	Application circuit modified for RST/GPIO1 connection and Bootstrap setup internal circuit of module.	Jack	D
Mar 25 th ,2020	4.2.3: GPIO2/GPIO3 ; UART baud rate : 115200 5.2 AI76X7H BreakOut and Bootstrap setup internal circuit of module. Pin21 name change from 5GRF to GND 6. Dimension, Change to actually PCB pattern.	Jack	E

INDEX

1. Description.....	3
1.1. Platform Features	3
2. Hardware Spec.....	4
2.1 Specification.....	4
3. Hardware Feature Configuration	5
3.1. Power supply	5
3.2. LED.....	5
3.3. XBee Breakout Pin Definition.....	6
3.4. PINMUX Table	6
4. Configuring the HDK.....	7
4.1. Configuring the HDK to Normal mode	7
4.2. Configuring the HDK to Recovery mode	9
5. Schematics	10
5.1. XBee Interface.....	10
5.2. AI76X7H BreakOut and Bootstrap setup internal circuit of module.	11
5.3. EE Part	13
6. Dimension.....	15

1. Description

EK-AI7687HXB/EK-AI7697HXB/EK-AI7697HDXB is a low-cost and easy to use Internet of Things (IoT) development platform for RTOS to design, prototype, evaluate and implement IoT projects. It is based on AI76X7H series stamp Module, with ARM Cortex-M4 with floating point MCU in package. The HDK enables rich connectivity features, communication with cloud services and real-time control.

1.1. Platform Features

General

- ARM Cortex M4 MCU with FPU with up to 192MHz clock speed
- Embedded 352KB SRAM and 64KB boot ROM
Internal 2MB Flash
- Supports external serial flash with Quad Peripheral Interface (QPI) mode
- Supports eExecute In Place (XIP) on flash
- 32KB cache in XIP mode
- Two UART interfaces with hardware flow control and one UART for debug, all multiplexed with GPIO
- One SPI slave interface multiplexed with GPIO
- Two I2C master interface multiplexed with GPIO
- One I2S interface multiplexed with GPIO
- Four channel 12-bit ADC multiplexed with GPIO
- Dedicated high-performance 32-bit RISC CPU N9 up to 160MHz clock speed
- IEEE 802.11 b/g/n compliant
- Supports 20MHz,40MHz bandwidth in 2.4GHz
- Dual-band 1T1R mode with data rate up to 150Mbps
- Supports STBC, LDPC
- Greenfield, mixed mode, legacy modes support
- IEEE 802.11 d/e/h/i/k/r/w support
- Security support for WFA WPA/WPA2 personal, WPS2.0, WAPI
- Supports 802.11w protected managed frames

- QoS support of WFA WMM, WMM PS
- Integrated LNA, PA, and T/R switch
- Optional external LNA and PA support.
- RX diversity support with additional RX input



2. Hardware Spec

2.1 Specification

Model Name	EK-AI7687HXB / EK-AI7697HXB / EK-AI7697HDXB
Chipset	MT76X7 series
Core	ARM Cortex-M4 MCU
FPU Clock Speed	192MHz
SRAM	352KB
Flash	Internal 2MB / external 4MB / external 4MB
Power	5V / 3.3V / Li-ion Battery
Humidity	Operating : Operating : -20°C ~ +70°C (Non-Condensing) Storage : -40°C ~ +85°C (Non-Condensing)
Dimension	57mm X 24.5mm X 15mm (Typ.)
Package	PCBA

Top View :

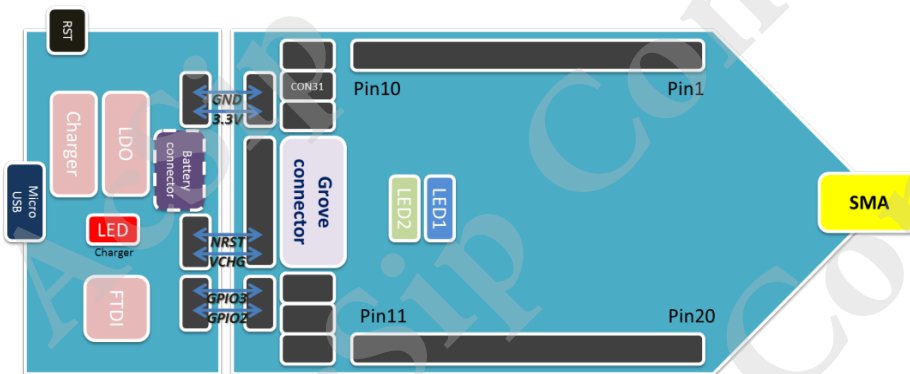

Bottom View :

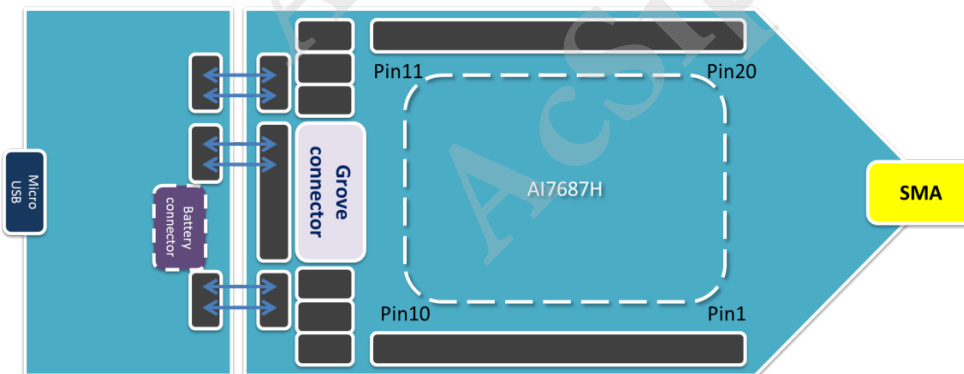

3. Hardware Feature Configuration

3.1. Power supply

EK-AI7687HXB / EK-AI7697HXB / EK-AI7697HDXB support three ways for power supply.

1. Micro USB 5V

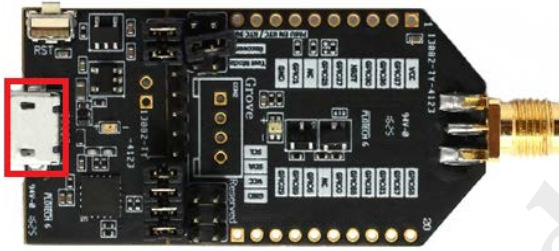

2. BAT_CONN 3.7V Li-Ion Battery



3. 3.3V power supply

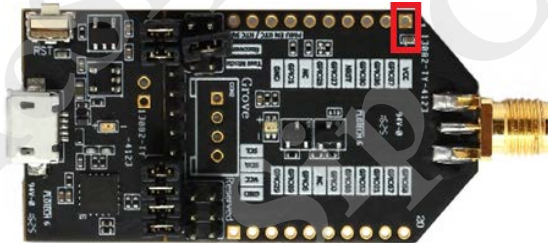

3.2. LED

There has two LEDs on PCBA.

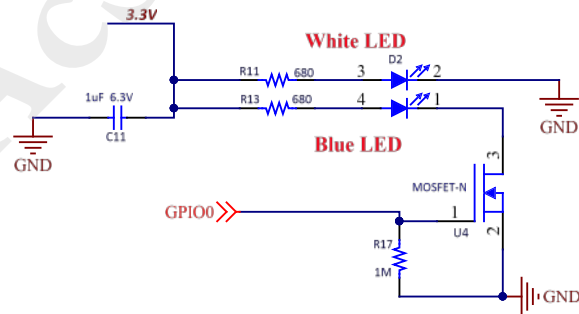

3.3. XBee Breakout Pin Definition

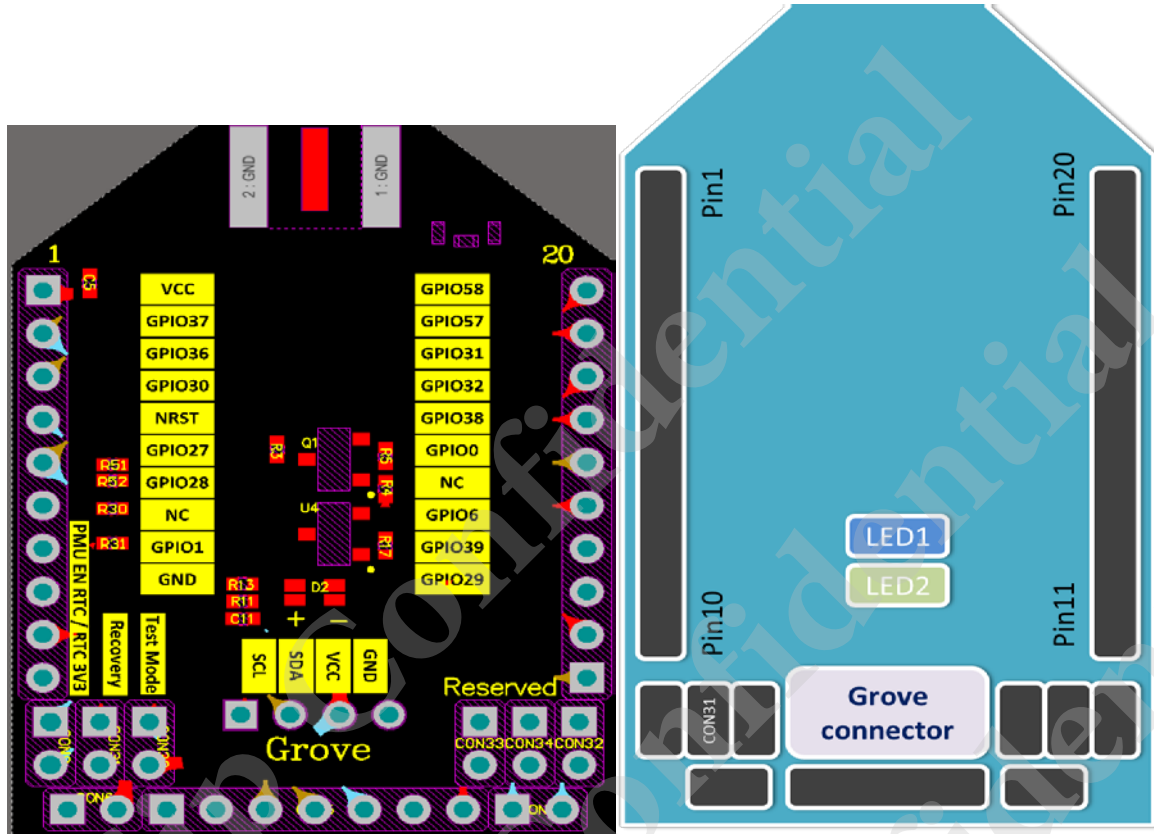

3.4. PINMUX Table

PIN No.	PIN Name	0	1	2	3	4	5	6	7	8	9
1	GPIO29				WIC[3]	I2S_MCLK (O)	I2S_MCLK (O)	SPI_MOSI_S_CM4 (I)	SPI_MOSI_M_CM4 (O)	GPIO[29] (I/O)	PWM[30] (O)
2	GPIO30					I2S_FS (I)	I2S_FS_M (O)	SPI_MISO_S_CM4 (O)	SPI_MISO_M_CM4 (I)	GPIO[30] (I/O)	PWM[31] (O)
3	GPIO28					I2C1_DATA (I/O)	SWD_CLK (I)			GPIO[28] (I/O)	PWM[29] (O)
4	GPIO27			PULSE_CNT (I)	WIC[2]	I2C1_CLK (I/O)	SWD_DIO (I/O)		I2C1_CLK (I/O)	GPIO[27] (I/O)	PWM[28] (O)
6	GPIO60	ADC_IN3		PULSE_CNT (I)	WIC[11]			SWD_CLK (I)		GPIO[60] (I/O)	PWM[39] (O)
7	GPIO59	ADC_IN2			WIC[10]			SWD_DIO (I/O)		GPIO[59] (I/O)	PWM[38] (O)
8	GPIO58	ADC_IN1			WIC[9]					GPIO[58] (I/O)	PWM[37] (O)
9	GPIO57	ADC_IN0			WIC[8]					GPIO[57] (I/O)	PWM[36] (O)
10	GPIO39	PULSE_CNT (I)			EINT[22]			SWD_CLK (I)	UART2_CTS_CM4 (I)	GPIO[39] (I/O)	PWM[22] (O)
12	GPIO38				EINT[21]			SWD_DIO (I/O)	UART2_RTS_CM4 (O)	GPIO[38] (I/O)	PWM[21] (O)
13	GPIO37				EINT[20]				UART2_TX_CM4 (O)	GPIO[37] (I/O)	PWM[20] (O)
15	GPIO36				WIC[7]				UART2_RX_CM4 (I)	GPIO[36] (I/O)	PWM[19] (O)
16	GPIO35				EINT[19]		I2S_TX (O)		UART_DBG_CM4 (O)	GPIO[35] (I/O)	PWM[18] (O)
17	GPIO34	FRAME_SYNC (I)			WIC[6]			SWD_CLK (I)	IR_RX (I)	GPIO[34] (I/O)	PWM[15] (O)
18	GPIO33	PULSE_CNT (I)			WIC[5]			SWD_DIO (I/O)	IR_TX (O)	GPIO[33] (I/O)	PWM[14] (O)
23	GPIO0				EINT[0]				UART1_RTS_CM4 (O)	GPIO[0] (I/O)	PWM[0] (O)
24	GPIO1				EINT[1]				UART1_CTS_CM4 (I)	GPIO[1] (I/O)	PWM[1] (O)
25	GPIO2				WIC[0]	SWD_CLK (I)			UART1_RX_CM4 (I)	GPIO[2] (I/O)	PWM[23] (O)
26	GPIO3			PULSE_CNT (I)	EINT[2]	SWD_DIO (I/O)			UART1_TX_CM4 (O)	GPIO[3] (I/O)	PWM[24] (O)
27	GPIO6				EINT[5]				SPI_CS_1_M_CM4 (O)	GPIO[6] (I/O)	PWM[4] (O)
28	GPIO7				EINT[6]		SPI_MISO_S_CM4 (O)	SPI_CS_0_M_CM4 (O)	SPI_CS_EXT (O)	GPIO[7] (I/O)	PWM[5] (O)
29	GPIO5				EINT[4]				SPI_DATA1_EXT (I/O)	GPIO[5] (I/O)	PWM[3] (O)
30	GPIO24					I2C2_CLK (I/O)	SPI_MOSI_S_CM4 (I)	SPI_MOSI_M_CM4 (O)	SPI_DATA2_EXT (I/O)	GPIO[24] (I/O)	PWM[25] (O)
31	GPIO25			FRAME_SYNC (I)	WIC[1]	I2C2_DATA (I/O)	SPI_SCK_S_CM4 (I)	SPI_MISO_M_CM4 (I)	SPI_DATA3_EXT (I/O)	GPIO[25] (I/O)	PWM[26] (O)
32	GPIO26					I2S_TX (O)	SPI_CS_0_S_CM4 (I)	SPI_SCK_M_CM4 (O)	SPI_CLK_EXT (O)	GPIO[26] (I/O)	PWM[27] (O)
33	GPIO4								SPI_DATA0_EXT (I/O)	GPIO[4] (I/O)	PWM[2] (O)
37	GPIO32				WIC[4]	I2S_BCLK (I)	I2S_BCLK_M (O)	SPI_CS_0_S_CM4 (I)	SPI_CS_0_M_CM4 (O)	GPIO[32] (I/O)	PWM[33] (O)
38	GPIO31					I2S_RX (I)	I2S_TX (O)	SPI_SCK_S_CM4 (I)	SPI_SCK_M_CM4 (O)	GPIO[31] (I/O)	PWM[32] (O)

4. Configuring the HDK

HDK includes a main board and a relative AI76X7H series stamp module. The stamp module is mounted on the PCBA bottom side. The simple steps to start-up EVK is shown as below:

1. CON6 is connector GND
2. CON3 is connector 3.3V (module power supply)
3. CON7 is connector RST button to module NRST pin
4. CON4 is connector UART RX
5. CON1 is connector UART TX

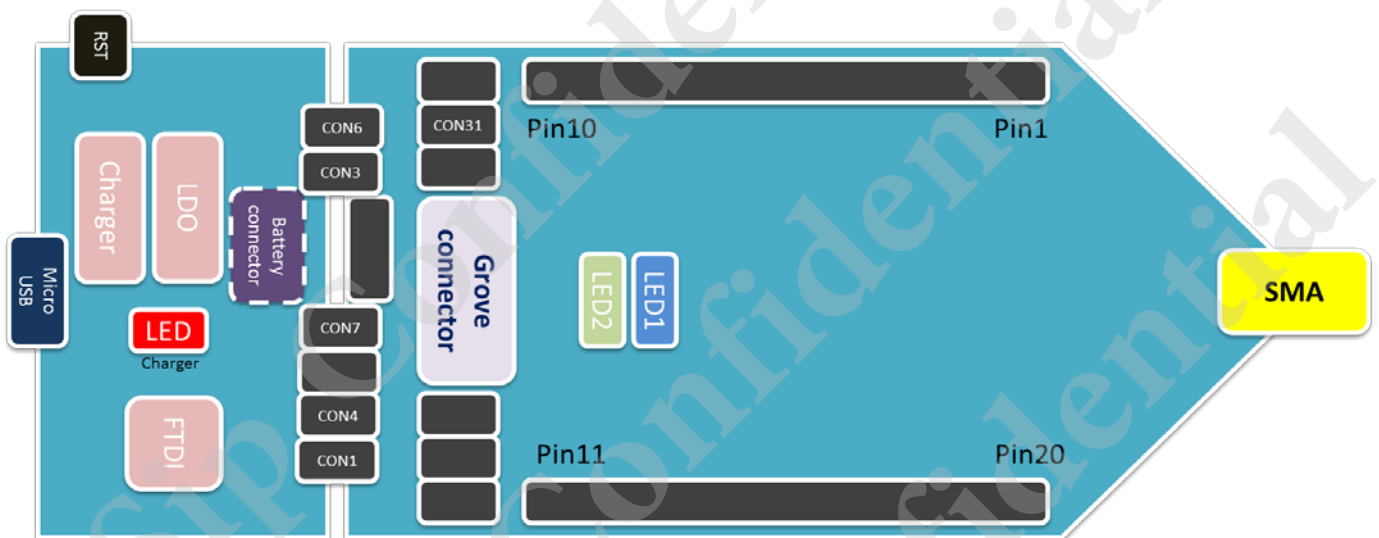

4.1. Configuring the HDK to Normal mode

1. Make sure that CON31 has no jumper on it.
2. Connect computer and EVK via micro USB cable.
3. On board FTDI chip transfers module TTL signal to PC USB port.
(GPIO2/GPIO3 ; UART baud rate : 115200)
4. Micro USB is debug UART and it can apply AT Command in RTOS environment.

FOR Example :

- Station Mode

Connect to "AcSiP_Public" AP

- Change the Operation Mode to Station Mode:

wifi config set opmode 1

- Set SSID:

wifi config set ssid 0 AcSiP_Public

- Configure auth information:

wifi config set psk 0 7 8 "acsip@public"

- The parameter definition of **wifi config set psk**:

wifi config set psk [port] [auth mode] [encrypt type] [psk key]

Combination Type	Auth Mode	Encrypt Type
OPEN	0	1
WPA2PSK(AES)	7	6
WPA2PSK(TKIP)	7	4
WPA2PSK(AES+TKIP)	7	8
WPAPSK(AES)	4	6
WPAPSK(TKIP)	4	4
WPAPSK+WPA2PSK(AES+TKIP)	9	8
WEP(OPEN)	0	0

- Apply changes:

wifi config set reload

- Wait for few seconds, the message like below would show up if connecting to the AP successfully:

[T: 5066238 M: common C: INFO F: ip_change_call_back L: 441]: *****

[T: 5066239 M: common C: INFO F: ip_change_call_back L: 442]: DHCP got IP:192.168.20.67

[T: 5066239 M: common C: INFO F: ip_change_call_back L: 443]: *****

- Get RSSI:

wifi connect get rssi

● AP Mode

- Change the Operation Mode to AP Mode:

wifi config set opmode 2

- Change Wireless Mode:

wifi config set wirelessmode 1 [wireless mode]

mode:

- 0 -- 11BG mixed
- 1 -- 11B only
- 2 -- 11A only (5G band, not support)
- 3 -- 11A/B/G mixed (not supported)
- 4 -- 11G only
- 5 -- 11ABGN mixed (both band, not support)
- 6 -- 11N only in 2.4G
- 7 -- 11GN mixed
- 8 -- 11AN mixed (5G band, not support)
- 9 -- 11BGN mixed
- 10 -- 11AGN mixed (not support)
- 11 -- 11N 5G (not support)

- Change Country:

wifi config set country [band(0 for 2.4G, 1 for 5G)] [region]

Band	2.4G							
Region	0	1	2	3	4	5	6	7
CH	CH1-11	CH1-13	CH10-11	CH10-13	CH14	CH1-14	CH3-9	CH5-13

- Change Channel:

wifi config set ch 1 [channel number]

wifi config set reload

- Change Bandwidth:

wifi config set bw 1 [bandwidth(0 for 20MHz, 1 for 40MHz)]

- Get the Station List for analyzing the status of clients which connected to this AP:

wifi connect get stalist

- The response sample of Station List:

stalist size=1

0

last_tx_rate: MCS=7, LDPC=0, MODE=2

last_rx_rate: MCS=8, LDPC=0, MODE=1

rssi_sample.LastRssi0)=-25

rssi_sample.AvgRssi0X8=-200

addr=cc:3d:82:2c:c1:9e

power_save_mode=1

bandwidth=0

keep_alive=0

wifi_connection_get_sta_list, status:0

4.2. Configuring the HDK to Recovery mode

1. Setting the CON31 jumper and push RST button for Recovery mode.
(In Recovery mode , Debug UART message showed “ccc”)
2. Connect computer and EVK via micro USB cable.
3. On board FTDI chip transfers module TTL signal to PC USB port.
(GPIO2/GPIO3 ; UART baud rate : 115200)
4. In recovery mode ,there are two function can be used
 1. RF performance test (MTK QA tool)
 2. Update module image (MT76x7_Flash_Tool)

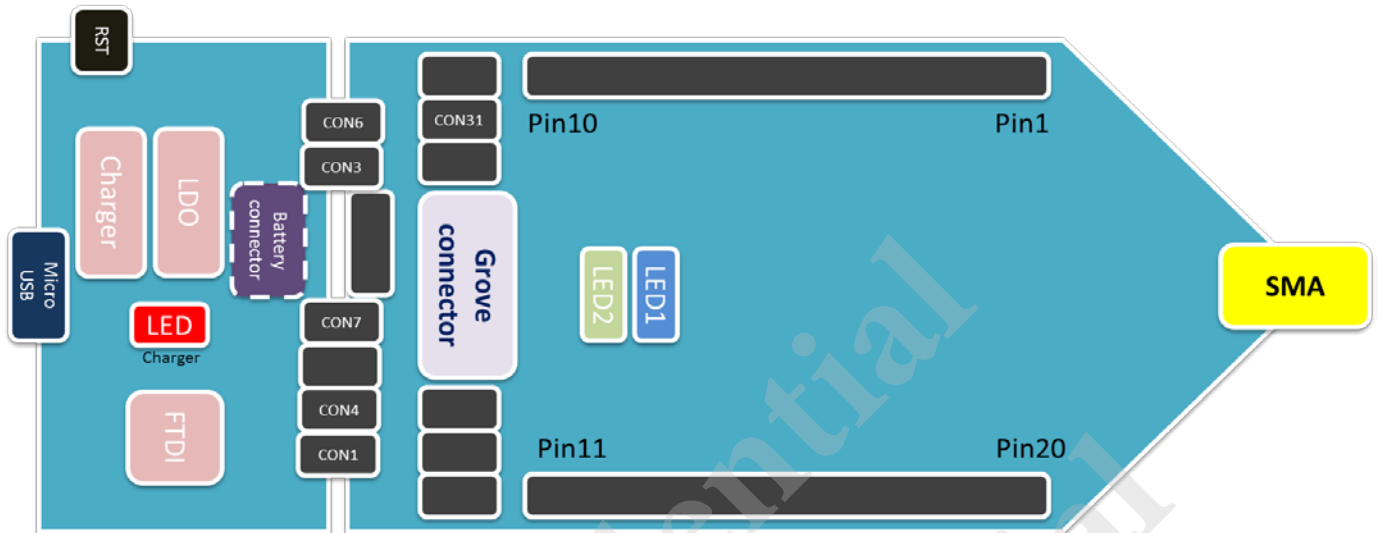

5. Schematics

Annotation: Module(RF I/O via pin20) used in this HDK is not standard one, if customer need RF I/O via pin20, please contact AcSiP sales, but the certification report will be ineffective.

5.1. XBee Interface

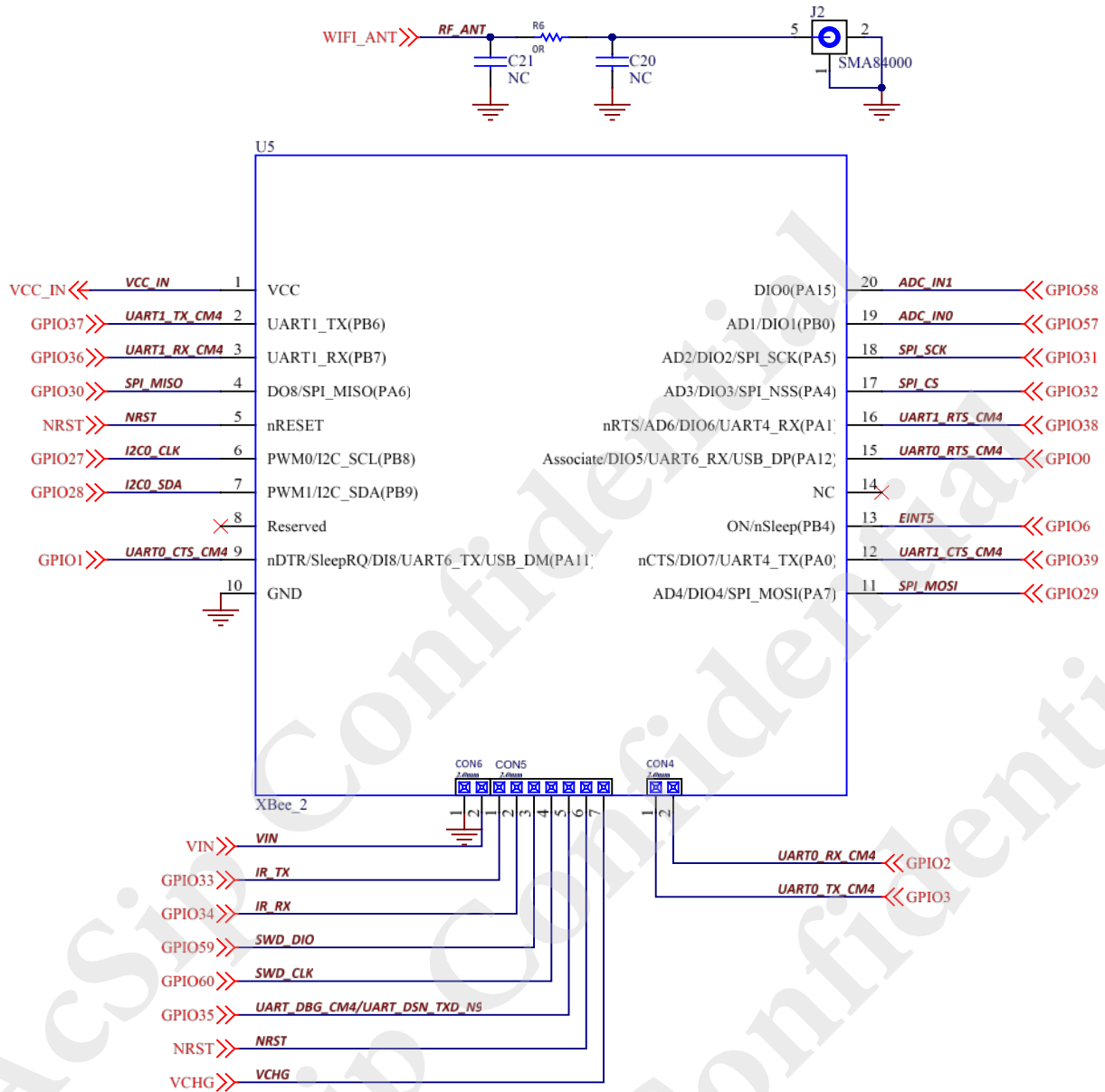

External Flash

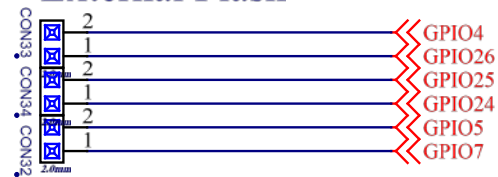

5.2. AI76X7H BreakOut and Bootstrap setup internal circuit of module.

[Please see AI76x7H series application circuit.pdf for more detail.](#)

GPIO1 is connected to NRST internal circuit.

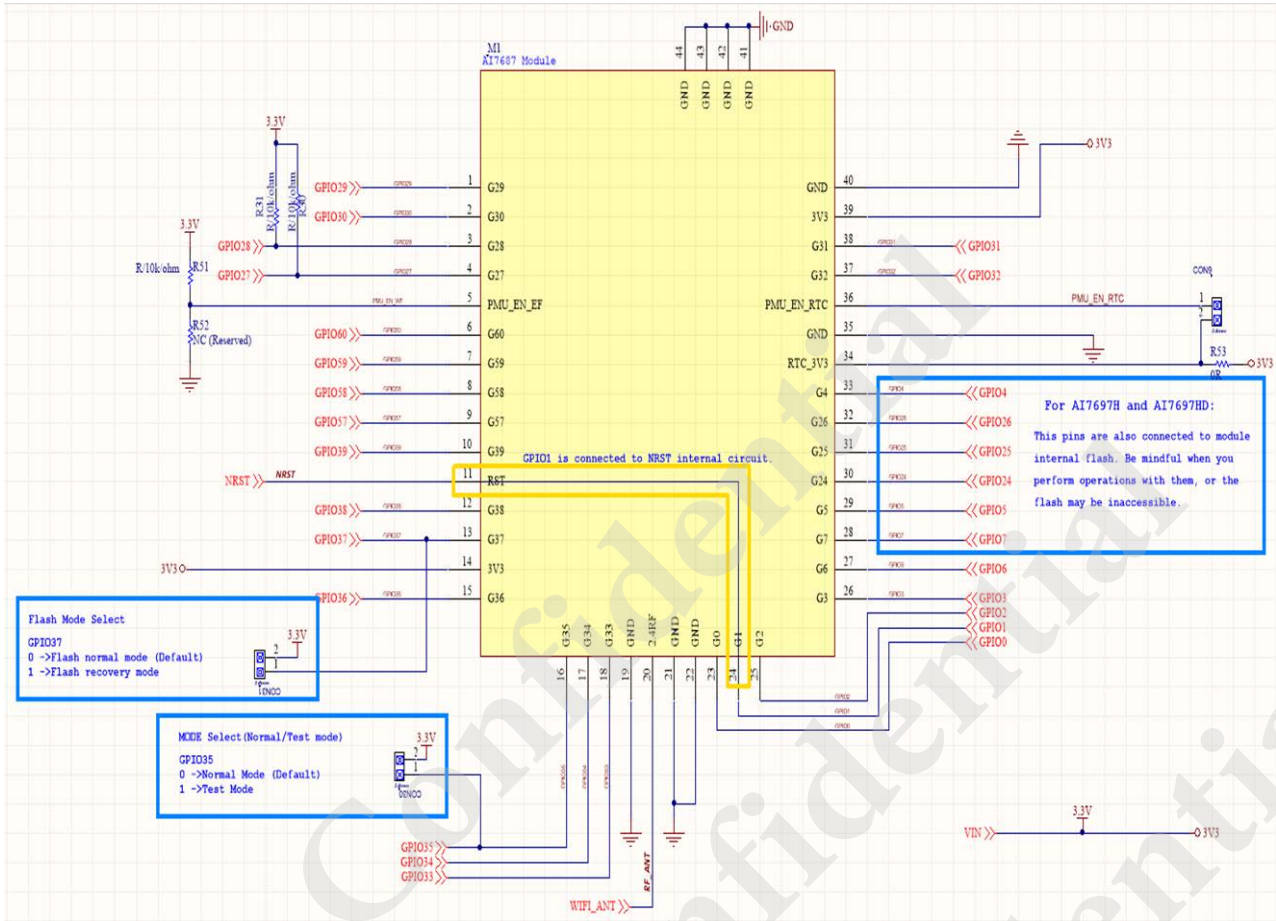

Bootstrap setup internal circuit of module

Strap Pin

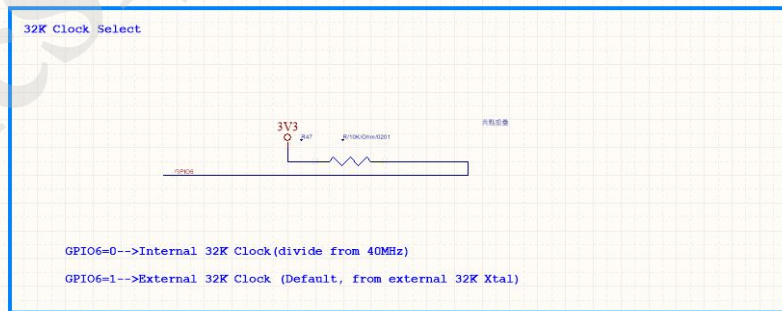
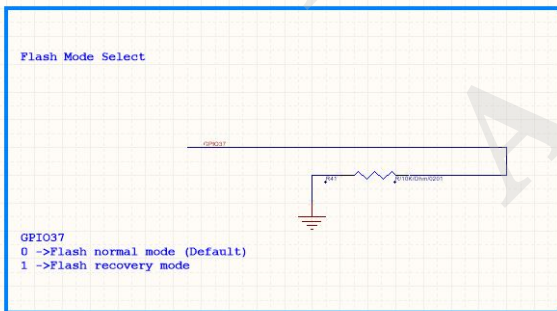
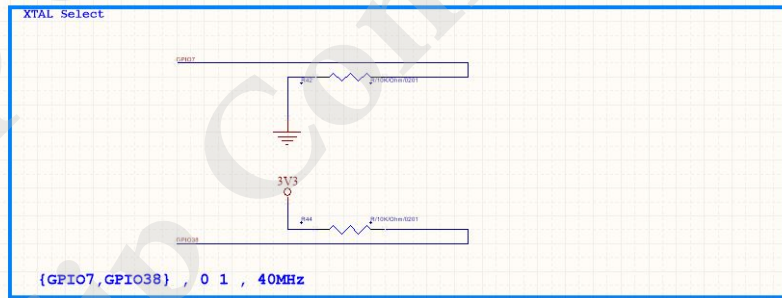
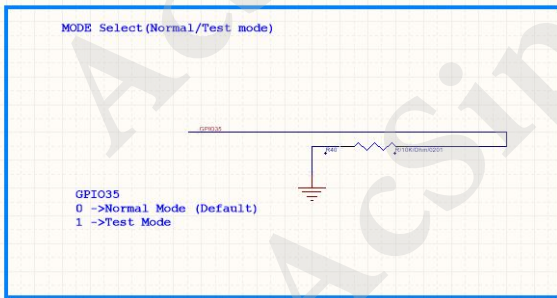

5.3. EE Part

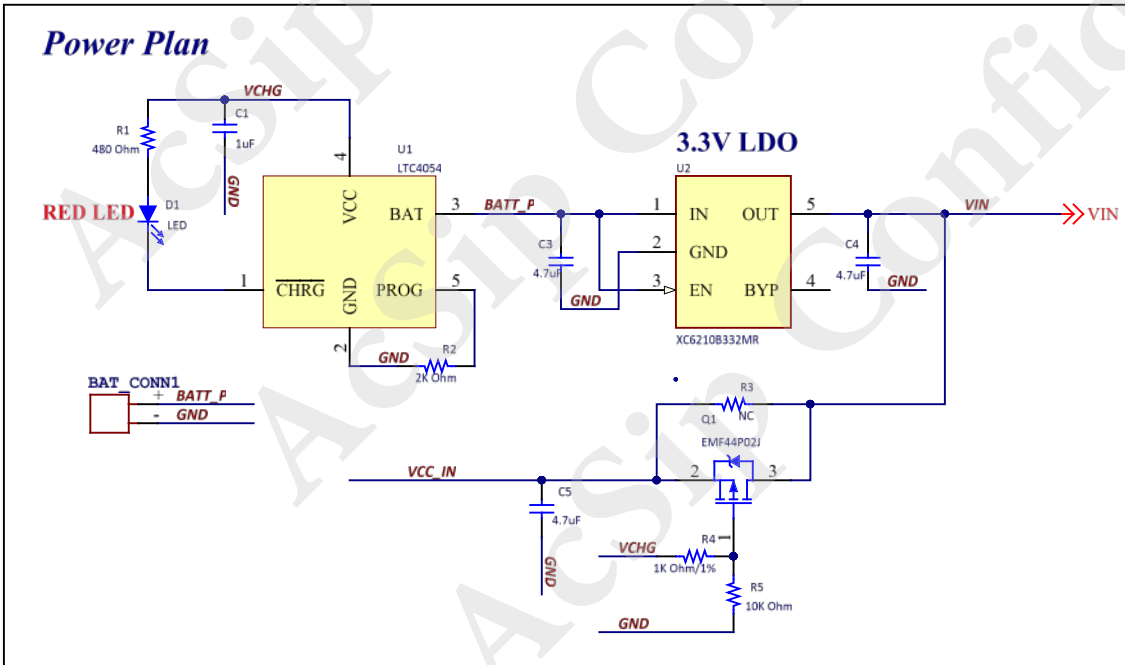
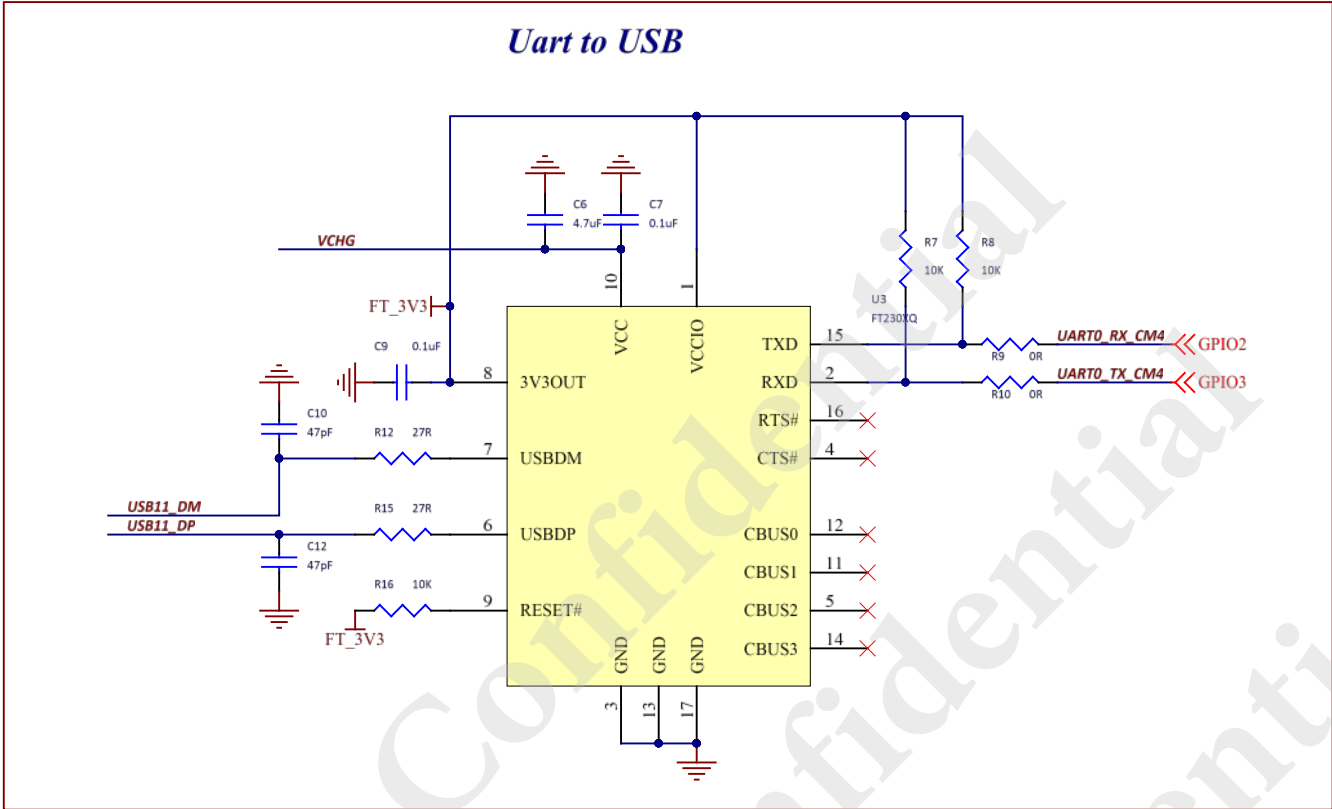

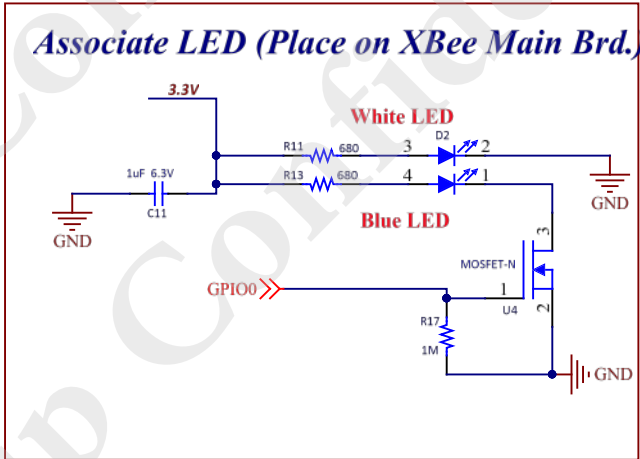
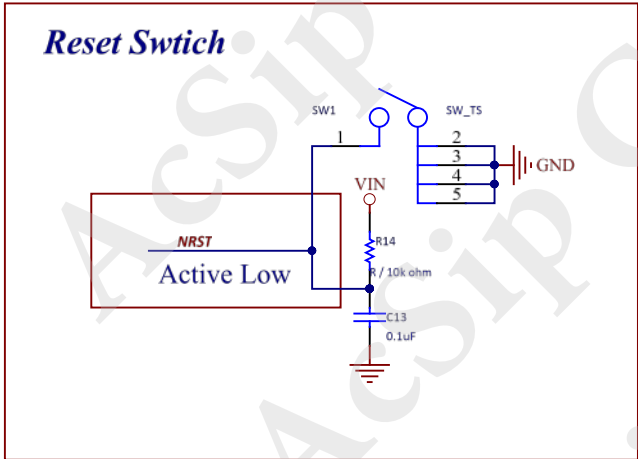
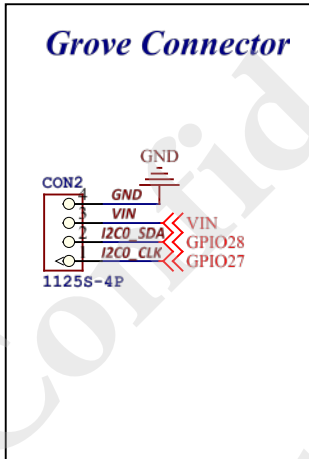
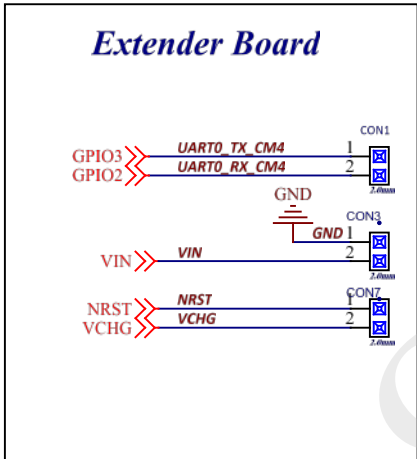
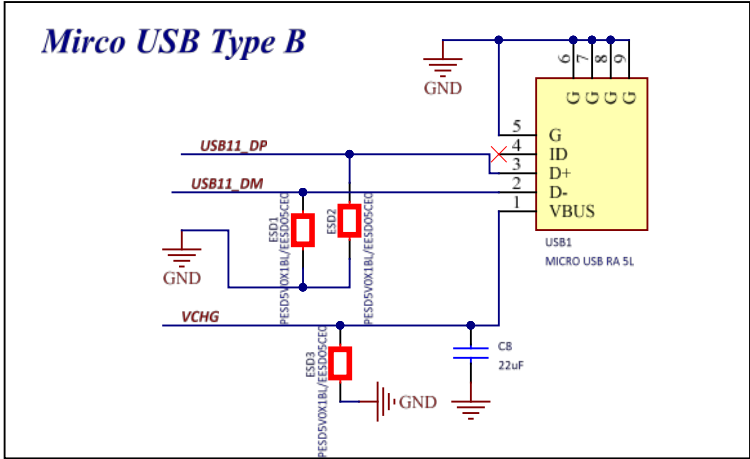

6. Dimension

